



# LIQUOR DISPLAYS

## MODULAR COMPONENTS

PROJECT \_\_\_\_\_

ITEM NO. \_\_\_\_\_

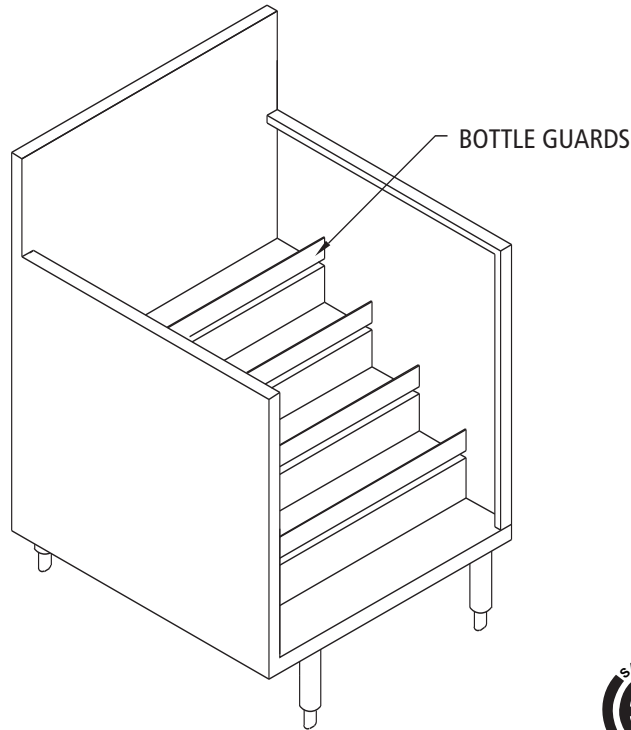

MODEL ILDD-24



### STANDARD FEATURES

- All Heli-arc welded construction
- All 18 gauge type 304, 18/8 stainless steel
- Heavy duty stainless steel gussets welded to 14 gauge stainless steel channel supports
- Stainless steel adjustable bullet feet
- Liquor steps are easily cleaned

### MODELS

#### 'D' SERIES 24" DEEP

<u>Length</u>	<u>Bottle Capacity</u>	<u>Model</u>
<input type="checkbox"/> 24"	.....30	.....ILDD-24
<input type="checkbox"/> 48"	.....60	.....ILDD-48

### OPTIONS

- LC Locking Cover
- M Modified - Custom
- BG Bottle Guards
- FT Flat Top

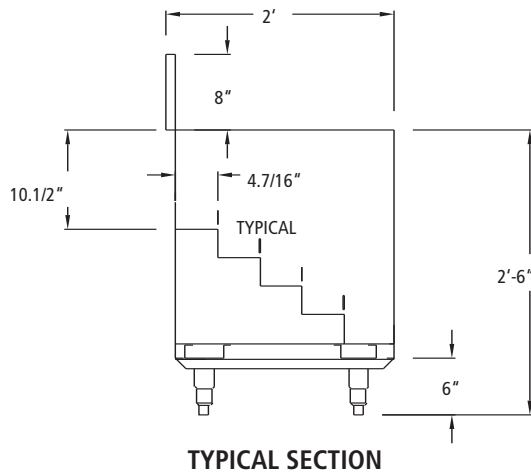
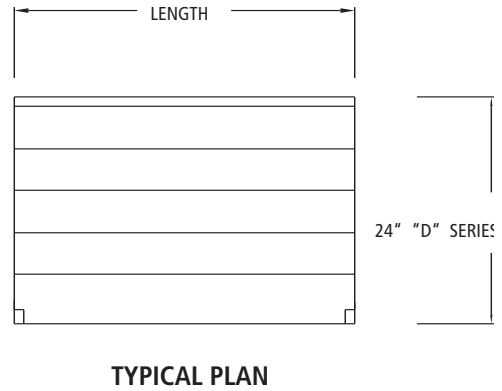
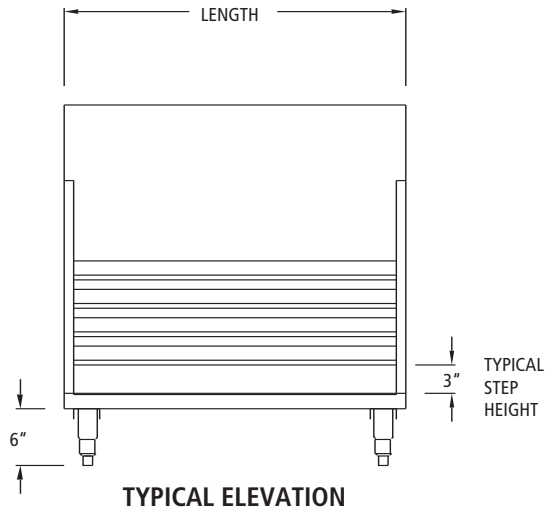

<b>'D' SERIES 24" DEEP</b>				
<b>LENGTH</b>	<b>BOTTLE CAPACITY</b>	<b>MODEL No.</b>	<b>WEIGHT</b>	<b>CUBE</b>
24"	30	ILDD-24	115	18
48"	60	ILDD-48	145	75